

BILL OF MATERIAL

SEQ. NO.	QTY	MARK	MINOR MARK	TOTAL UNIT	DESCRIPTION	LENGTH	STEEL GRADE	REMARKS	ADVANCE BILL#
33	1	3300T1		ONE	TRUSS				17
		3300T1		1	HSS18X6X1/2	57'-5 7/8"	A500-GR-B		
		hss56		2	HSS18X4X1/2	1'-9 3/4"	A500-GR-B	S2E	10
		hss88		2	HSS16X4X5/16	2'-11 11/16"	A500-GR-B		14
		hss182		2	HSS18X4X3/8	30'-5 5/16"	A500-GR-B		15
		hss353		2	HSS16X4X5/16	9'-9 1/2"	A500-GR-B		12
		p28		2	PL1/4"X3" 5/8"	1'-3 5/8"	A36		
		p67		2	PL1/4"X2"	0'-2"	A36		
		p96		8	PL1/4"X3"	0'-3"	A36		
		p112		2	PL1/4"X5" 5/8"	2'-0 1/4"	A36		
		p113		2	PL1/4"X5" 5/8"	3'-11 11/16"	A36		
		p163		1	PL1/4"X3" 1/2"	1'-0"	A36		
		p179		2	PL1/4"X3"	1'-0"	A36		
		p214		1	PL1"X5" 3/16"	1'-5 5/16"	A36		
		p365		2	PL3/4"X14"	2'-2"	A36		

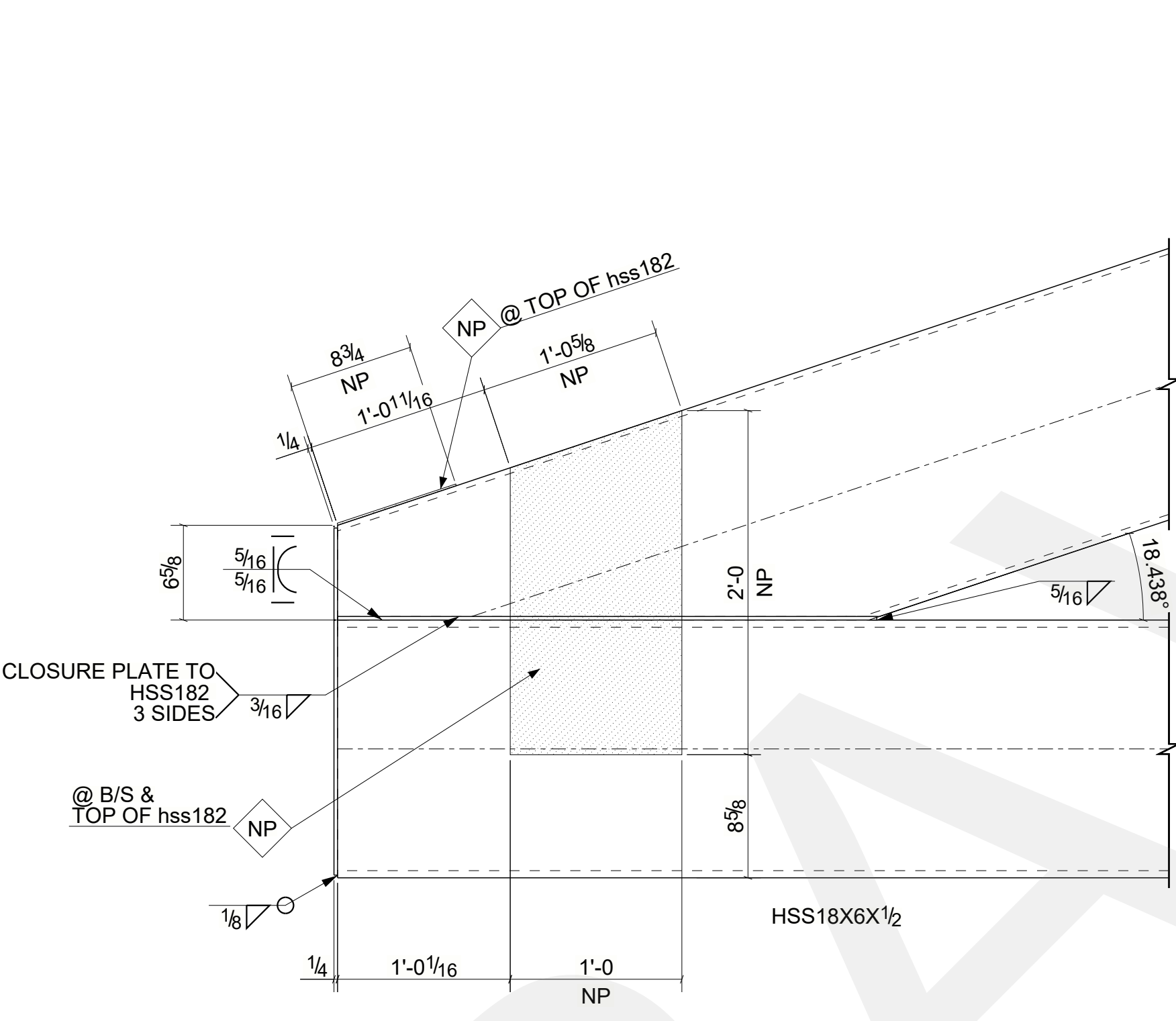

DETAIL-C
OTHERS NOT SHOWN FOR CLARITY

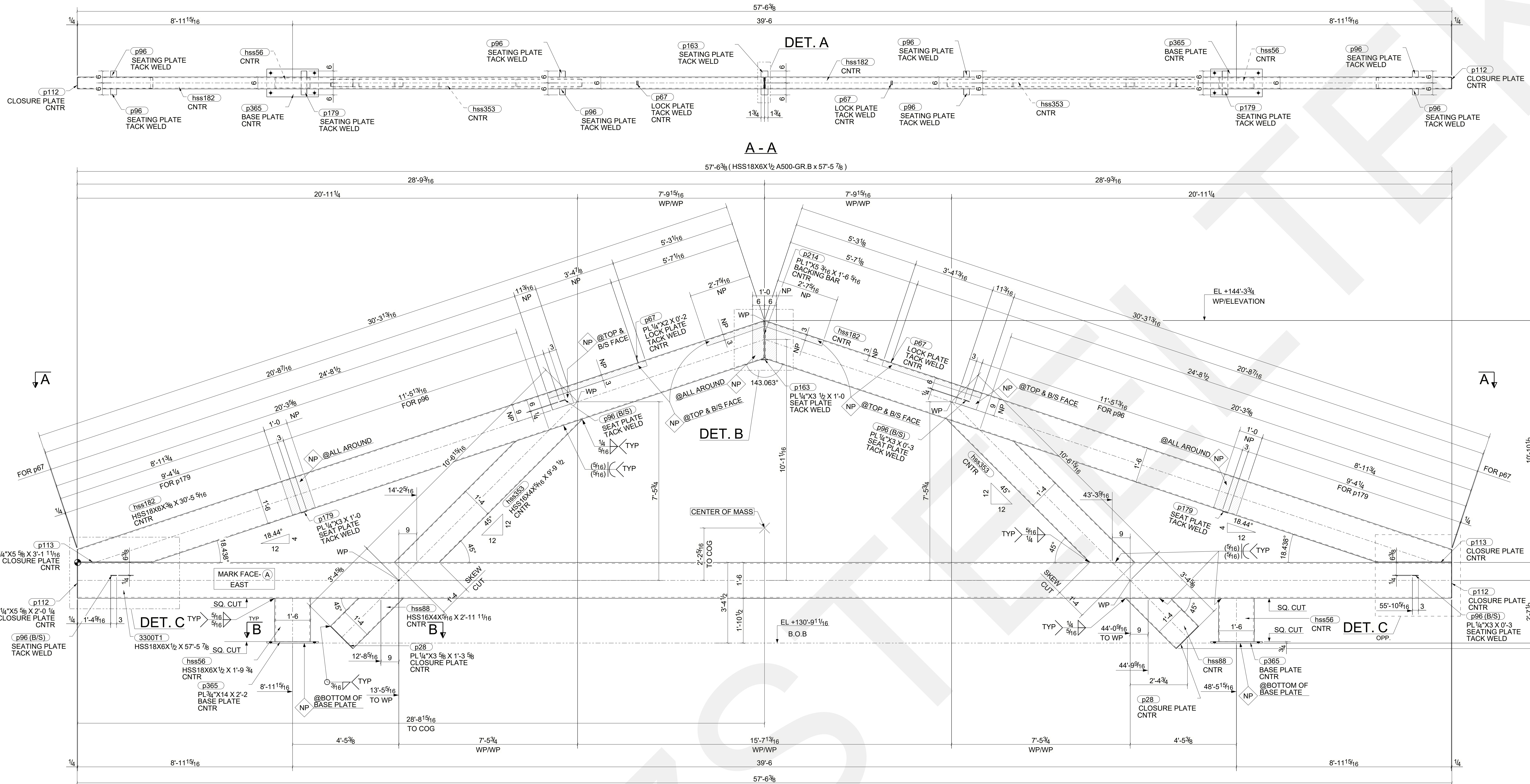
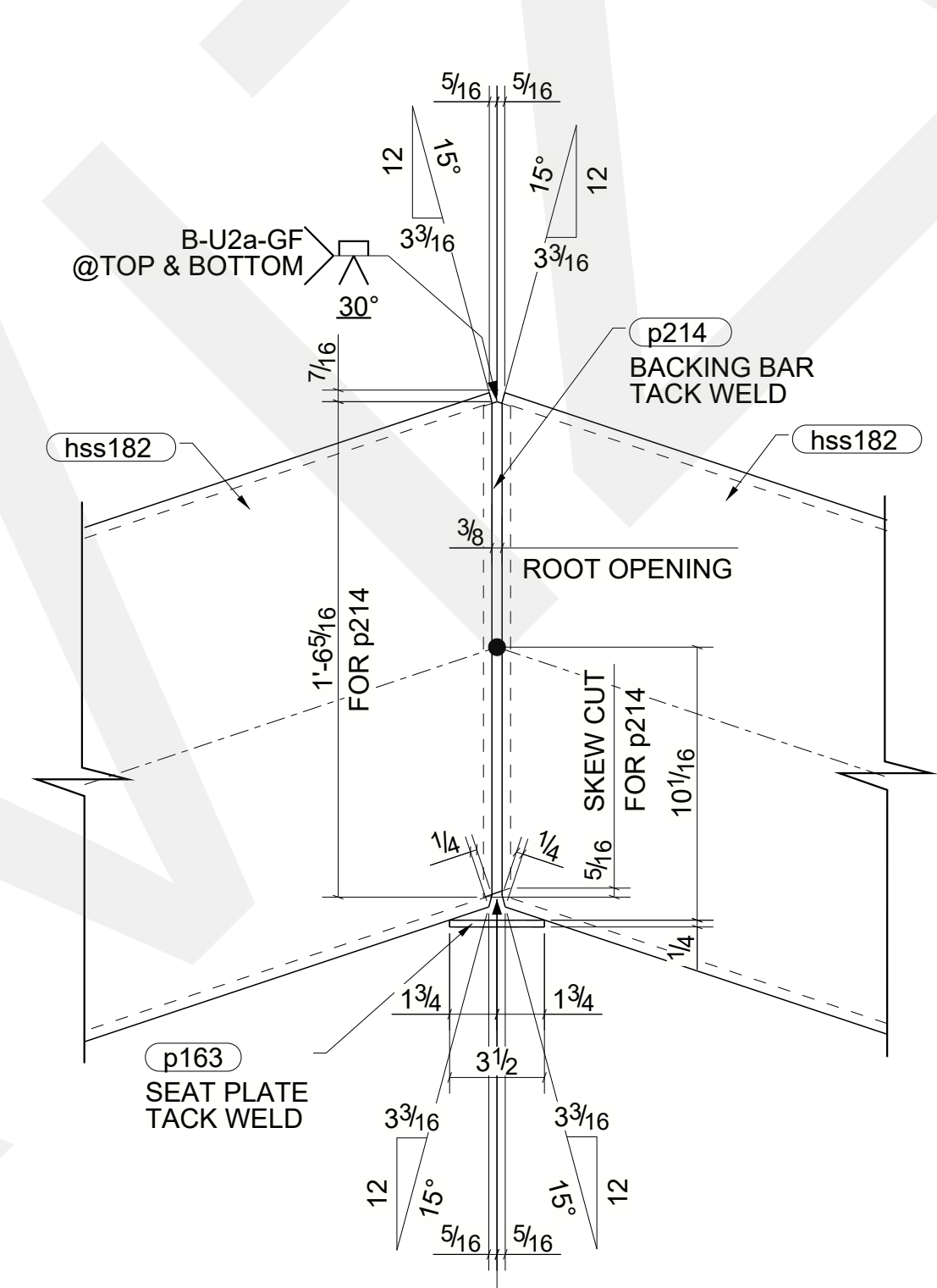

DETAIL-B

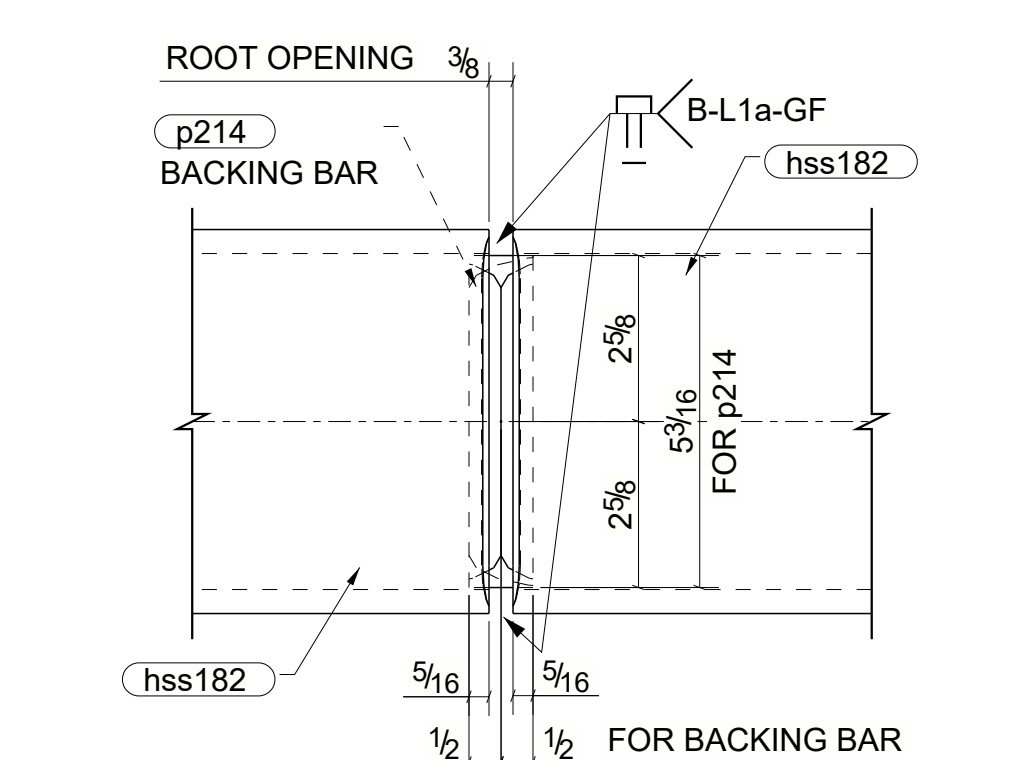

DETAIL-A
OTHERS NOT SHOWN FOR CLARITY

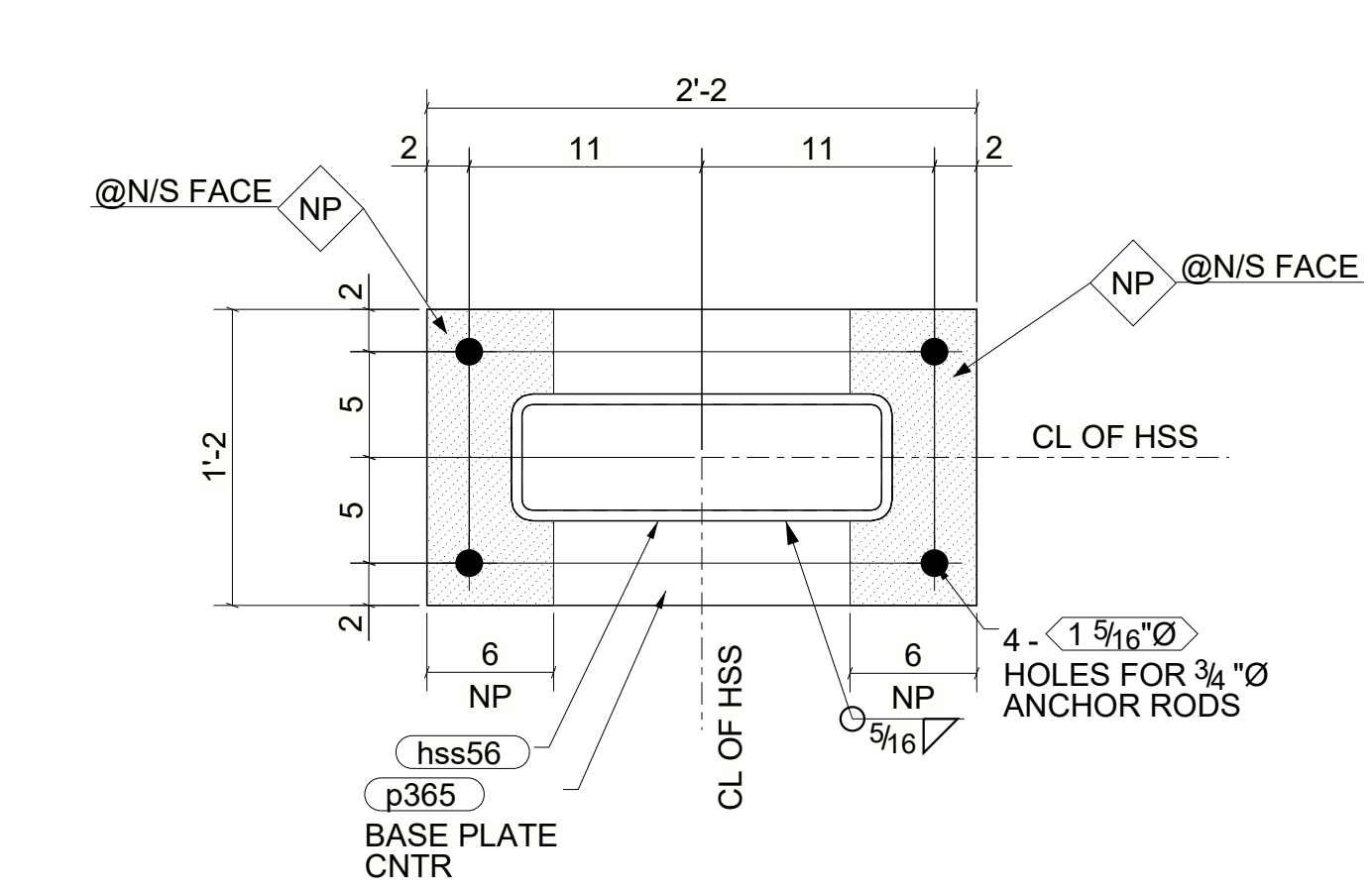

B-B

ONE-TRUSS-3300T1