

BILL OF MATERIAL

SEQ. NO.	SEQ. QTY	SHIP MARK	MINOR MARK	QTY TOTAL	QTY UNIT	DESCRIPTION MATERIAL	LENGTH FT. IN.	STEEL GRADE	REMARKS	ADVANCE BILL#
6075	1	2637F1		ONE		FRAME				3094
			2637F1	1	1	C6X13	23' 7 3/8"	A36		
			c19	6	6	C6X13	2' 5 9/16"	A36		3092
			c368	1	1	C6X13	23' 7 3/8"	A36		3094
			hss778	2	2	HSS6X2X3/16	2' 5 9/16"	A500-GR.B		3091
			p1321	20	20	FL1/4"X1 3/4"	0' 5 11/16"	A36		
			p1934	3	3	CP1/4X38"5/8	7' 10 1/4"	A36	PRE-GALV	

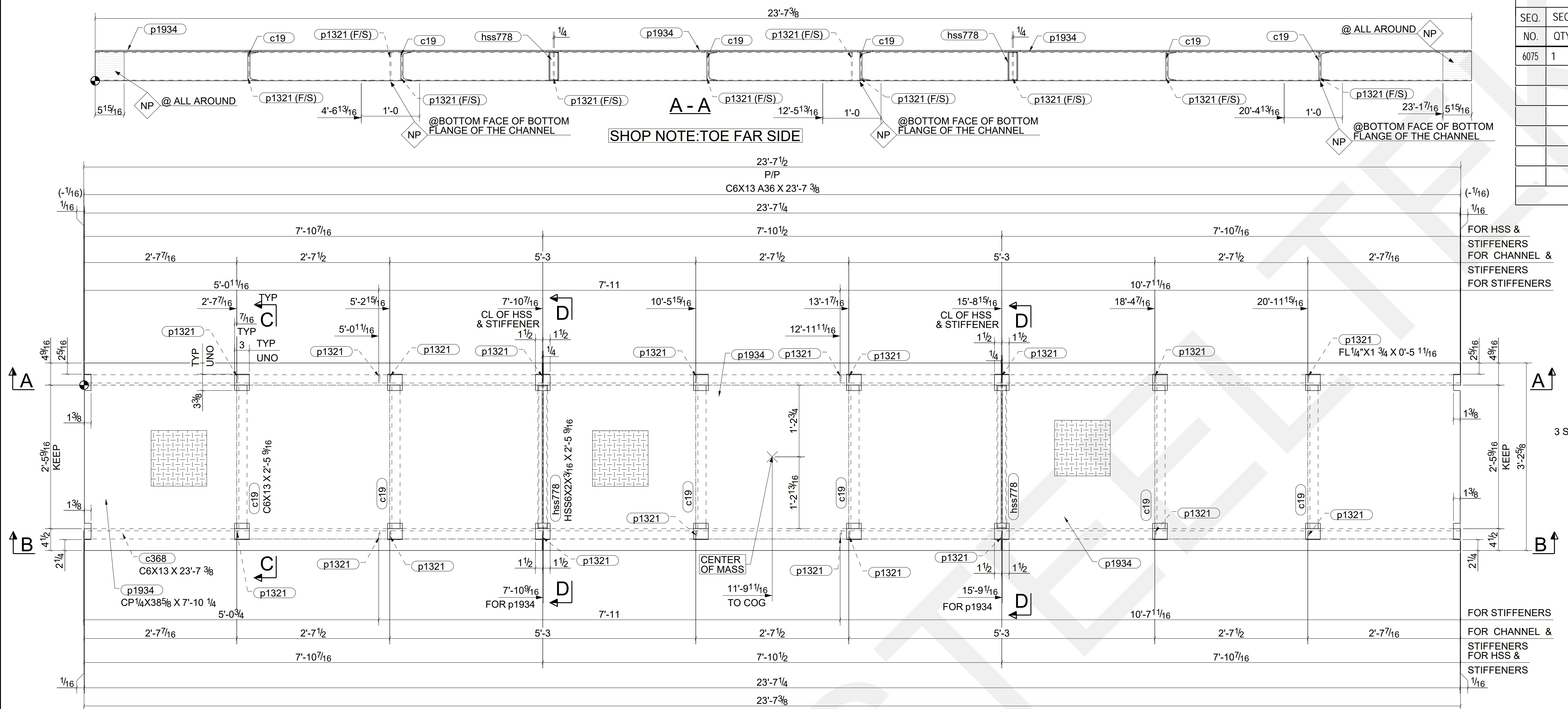

SHOP NOTE: TOE FAR SIDE

PLAN

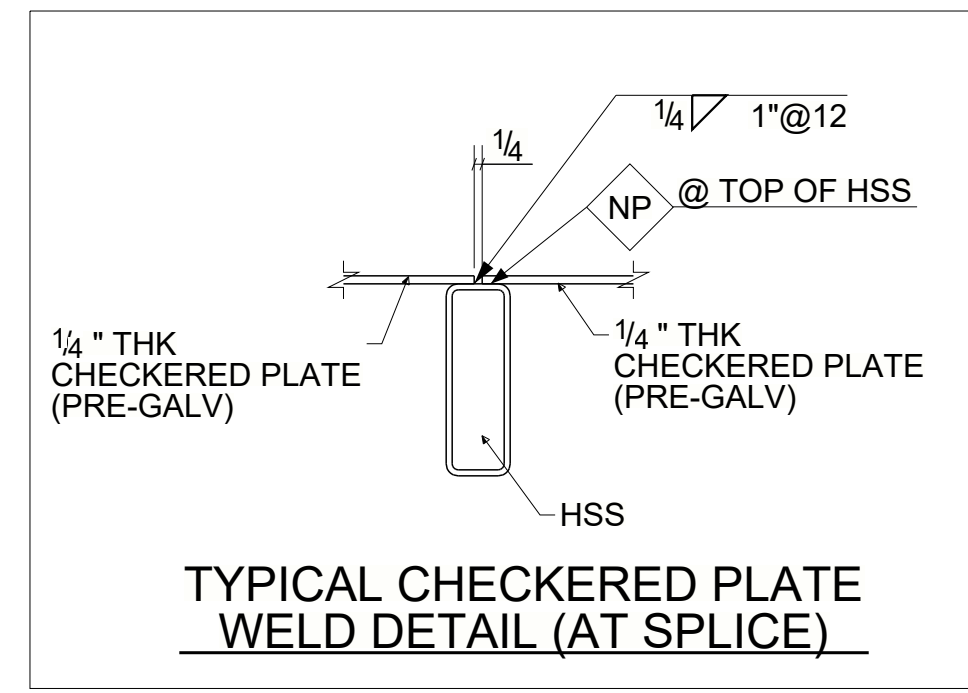
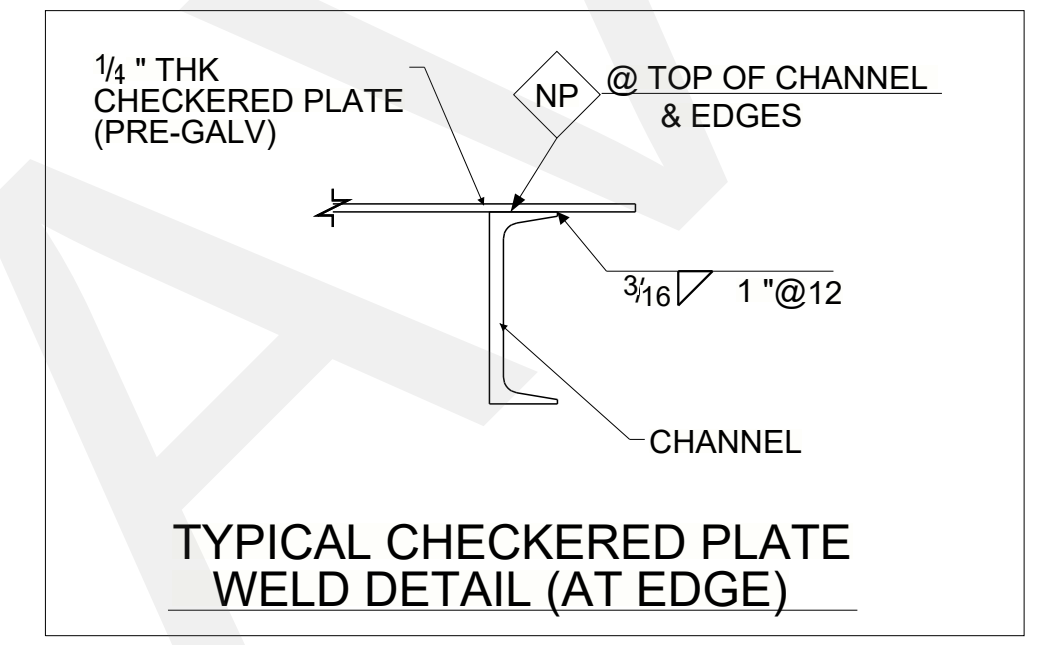
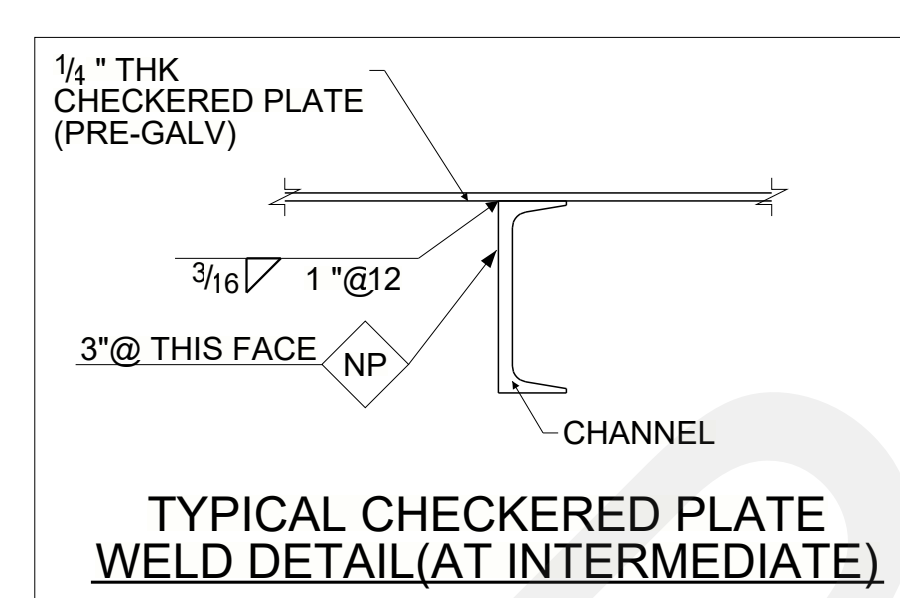
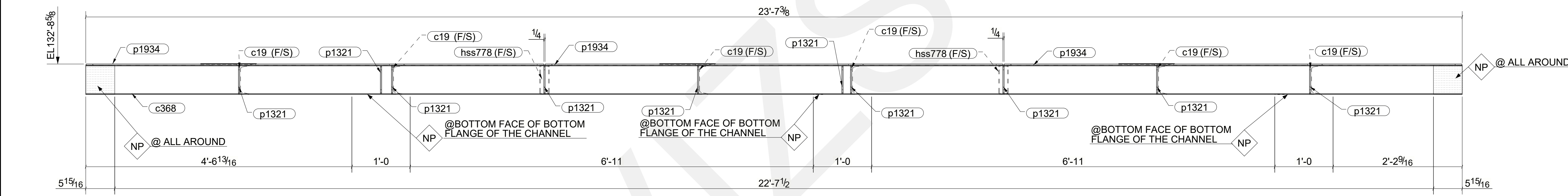
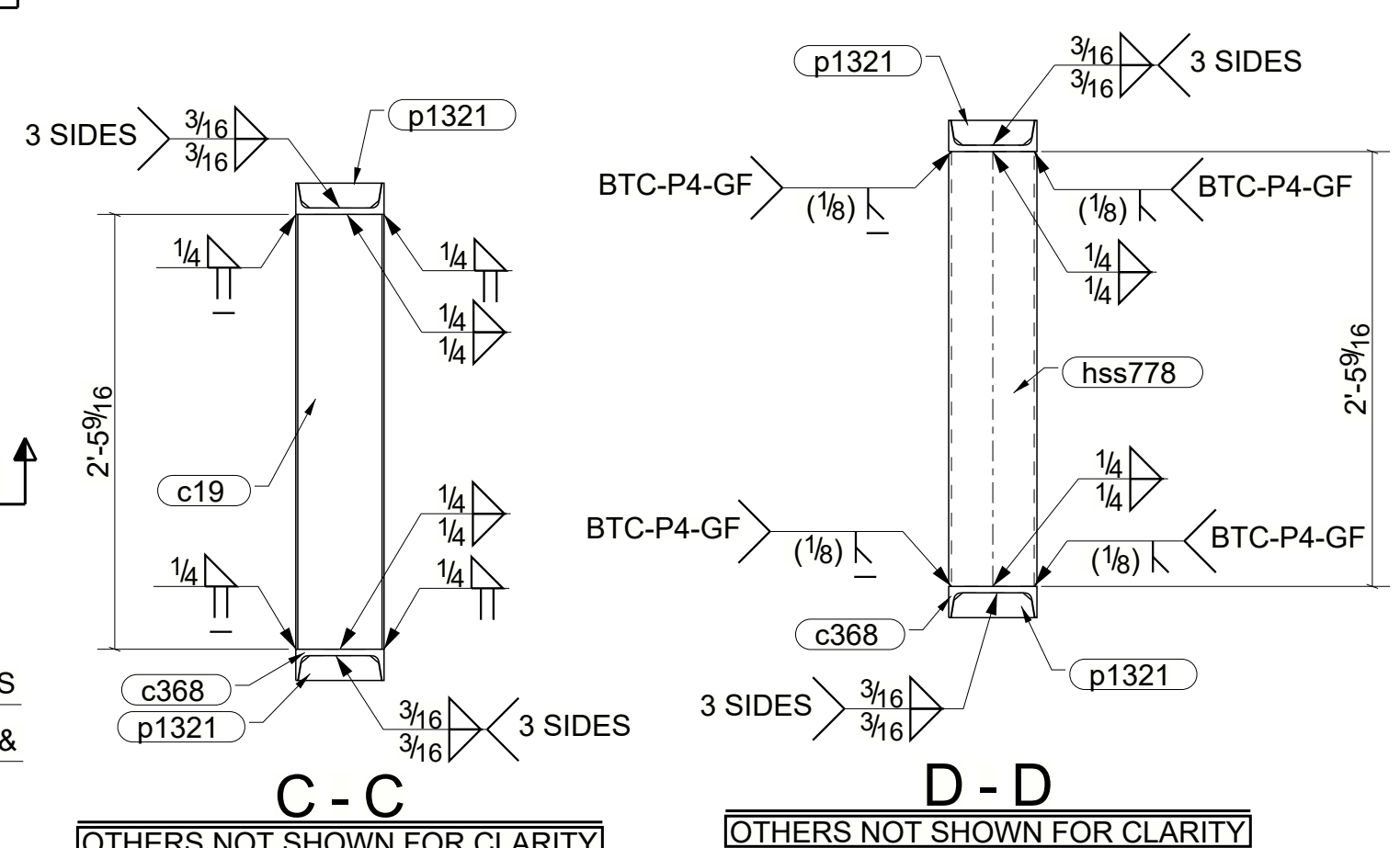

ONE-FRAME-2637F1

W	6"x7'16"
F	2 1/8"x5'16"
K	13'16"