

1 ~ HANDRAIL ~ 11A

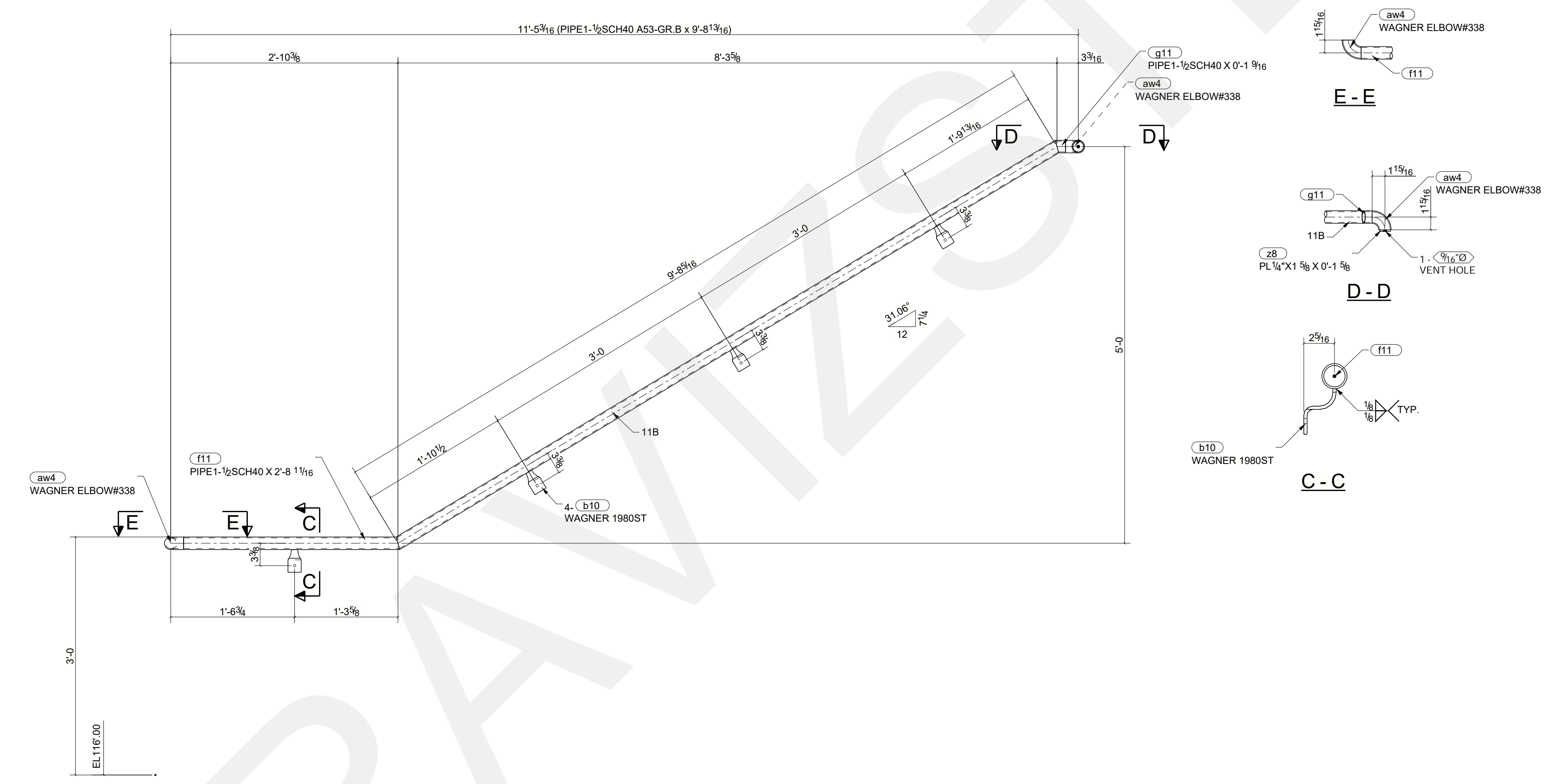

1 ~ HANDRAIL ~ 11B

BILL OF MATERIAL						FITTER	INSPECT.
SHIP MARK	PIECE MARK	QTY	DESCRIPTION	LENGTH	REMARKS		
11A		1	PIPE1-1/2SCH40	9'-8 13/16"	AS3-GR.B		
	aw4	1	WAGNER ELBOW#338	0'-3 1/16"	BUYOUT		
	b10	5	WAGNER 1980ST	0'-4 15/16"	BUYOUT		
	z8	1	PL1/4\"X1 5/8"	0'-1 5/8"	A36		
	b11	1	PIPE1-1/2SCH40	2'-7 7/16"	AS3-GR.B		
	c11	1	PIPE1-1/2SCH40	0'-2 13/16"	AS3-GR.B		
		5	3/8\"Ø MCMMASTER-CARR_94048A305 BOLT	0'-3 1/4"	Site		
11B		1	PIPE1-1/2SCH40	9'-8 13/16"	AS3-GR.B		
	aw4	2	WAGNER ELBOW#338	0'-3 1/16"	BUYOUT		
	b10	4	WAGNER 1980ST	0'-4 15/16"	BUYOUT		
	z8	1	PL1/4\"X1 5/8"	0'-1 5/8"	A36		
	f11	1	PIPE1-1/2SCH40	2'-8 11/16"	AS3-GR.B		
	g11	1	PIPE1-1/2SCH40	0'-1 9/16"	AS3-GR.B		
		4	3/8\"Ø MCMMASTER-CARR_94048A305 BOLT	0'-3 1/4"	Site		

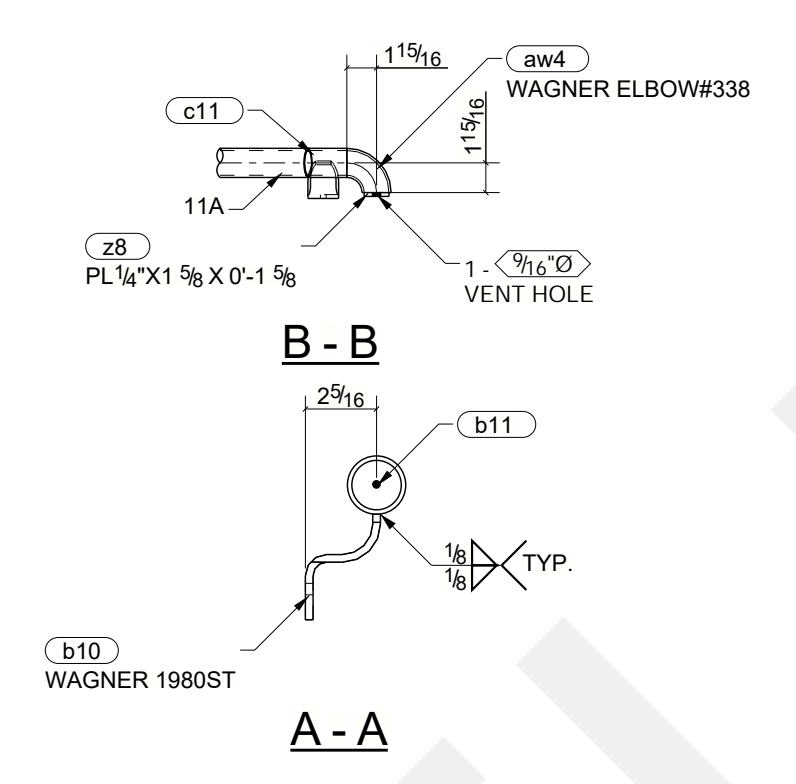

E - E

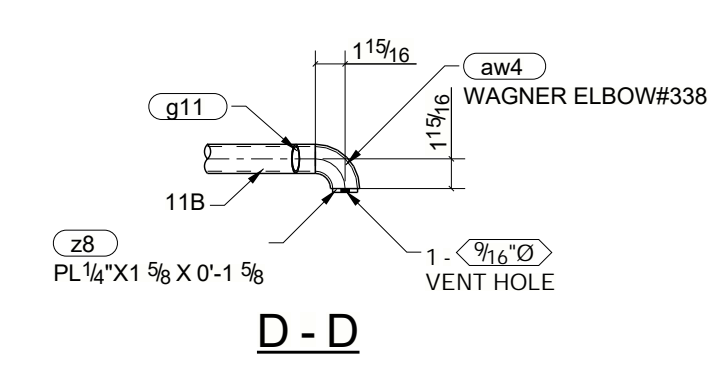

D - D

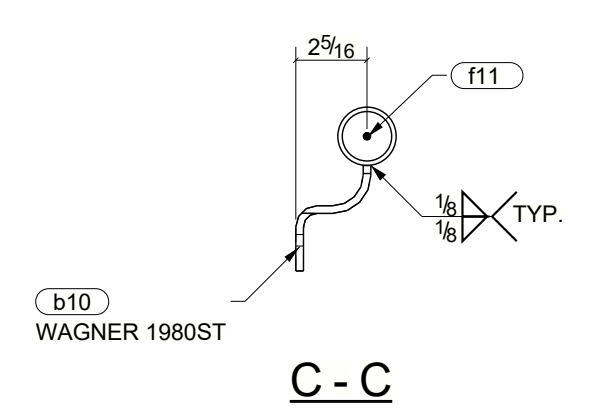

C - C

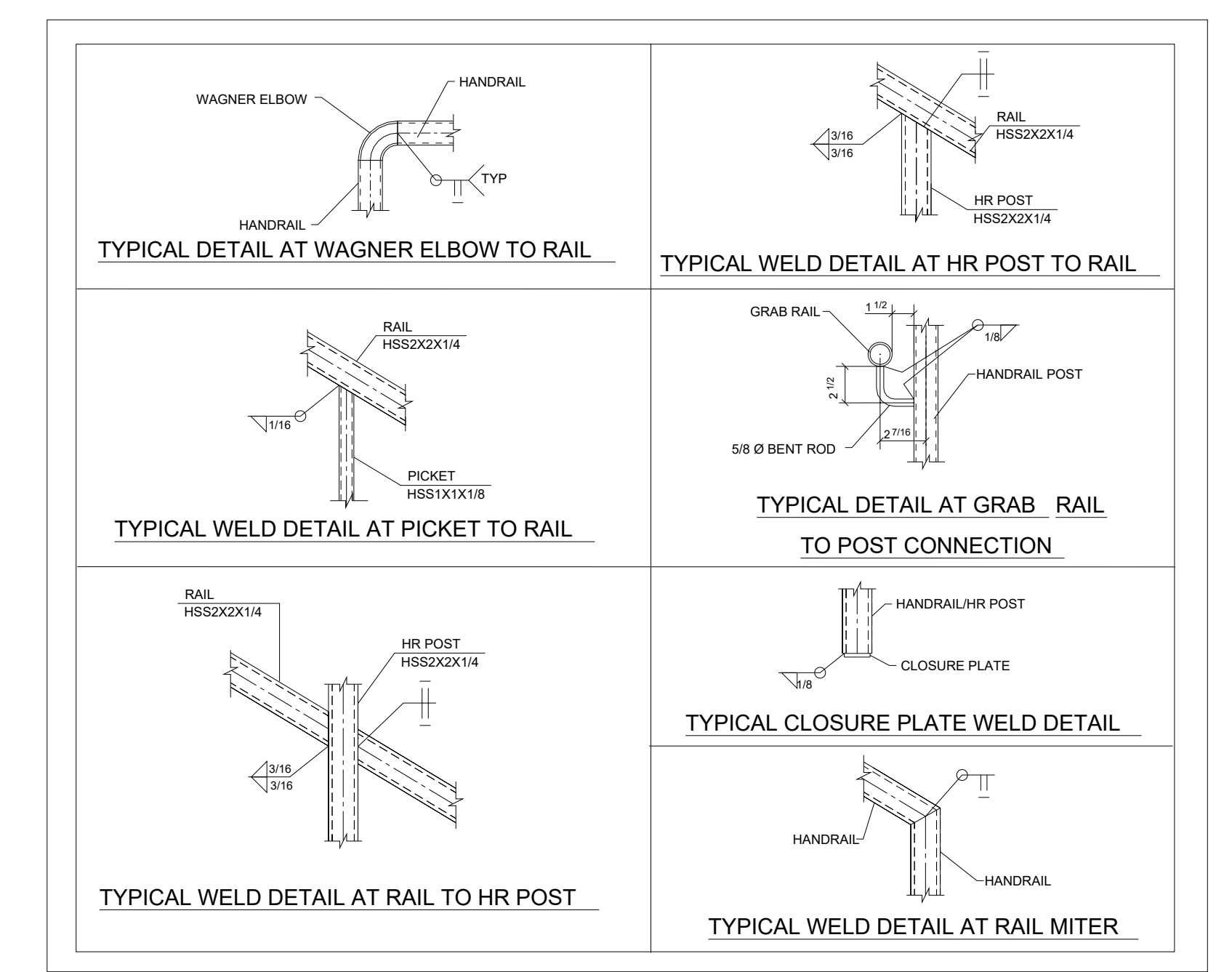

SHOP NOTE
 1. ALL JOINTS BE SEAL WELDED AS REQUIRED
 2. ALL EXPOSED VENT HOLES TO BE PLUGGED AFTER GALVANIZING
 3. PROVIDED VENT/DRAIN HOLES (AS REQUIRED) VISIBLE ON THE UNDERSIDE OF RAILS