

BILL OF MATERIAL						FITTER	INSPECT.
SHIP MARK	PIECE MARK	QTY	DESCRIPTION	LENGTH	REMARKS		
	9A	1	HSS2X2X1/4	8'-6 13/16"	A500-GR.C		
	aw4	1	WAGNER ELBOW#338	0'-3 1/16"	BUYOUT		
	a4	3	ROD5/8"	0'-4 1/2"	A36		
	aa8	1	PL3/8"X3"	0'-6 1/2"	A36		
	ab8	4	PL1/4"X1 3/4"	0'-1 3/4"	A36		
	ac8	3	PL3/8"X3"	0'-8"	A36		
	ad8	1	ROD5/8"	0'-4 1/2"	A36		
	z8	1	PL1/4"X1 5/8"	0'-1 5/8"	A36		
	a9	1	PIPE1-1/2SCH40	9'-0 5/8"	A53-GR.B		
	b9	1	PIPE1-1/2SCH40	3'-3 3/8"	A53-GR.B		
	w8	1	PIPE1-1/2SCH40	0'-3 5/16"	A53-GR.B		
	af8	1	HSS2X2X1/4	3'-11 5/16"	A500-GR.C		
	b8	1	HSS2X2X1/4	3'-5 15/16"	A500-GR.C		
	c8	1	HSS2X2X1/4	3'-11 15/16"	A500-GR.C		
	c9	1	HSS2X2X1/4	3'-11 5/8"	A500-GR.C		
	d9	1	HSS2X2X1/4	4'-0 3/8"	A500-GR.C		
	f8	1	HSS2X2X1/4	4'-0 5/16"	A500-GR.C		
	h8	1	HSS2X2X1/4	0'-1 3/4"	A500-GR.C		
	k8	1	HSS2X2X1/4	3'-3 1/2"	A500-GR.C		
	n8	18	HSS1X1X1/8	2'-9 1/4"	A500-GR.C		
	r8	1	HSS2X2X1/4	4'-1 3/8"	A500-GR.C		
	t8	8	HSS1X1X1/8	2'-11"	A500-GR.C		
		8	3/4"Ø A325N BOLT	0'-2"	Site		

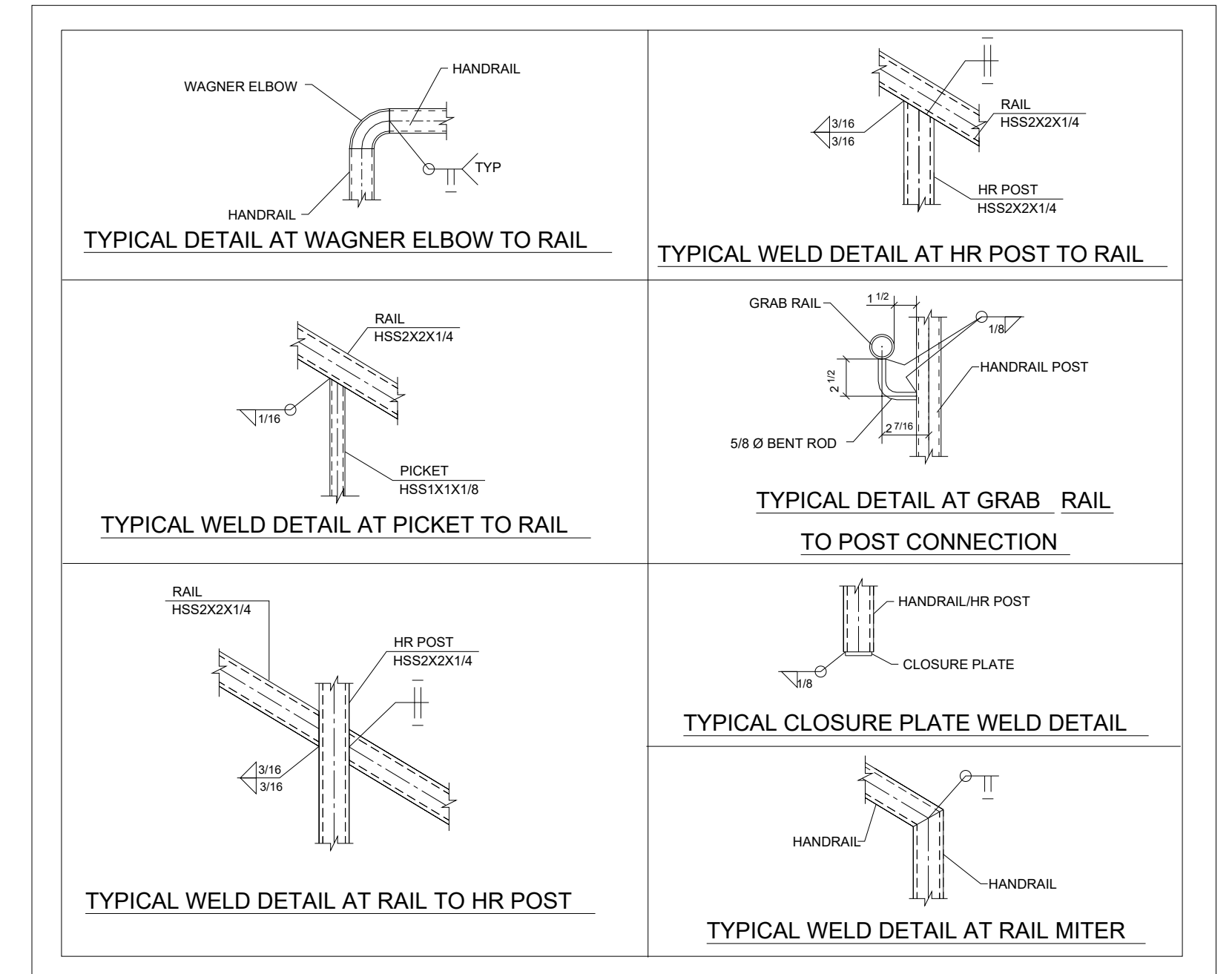
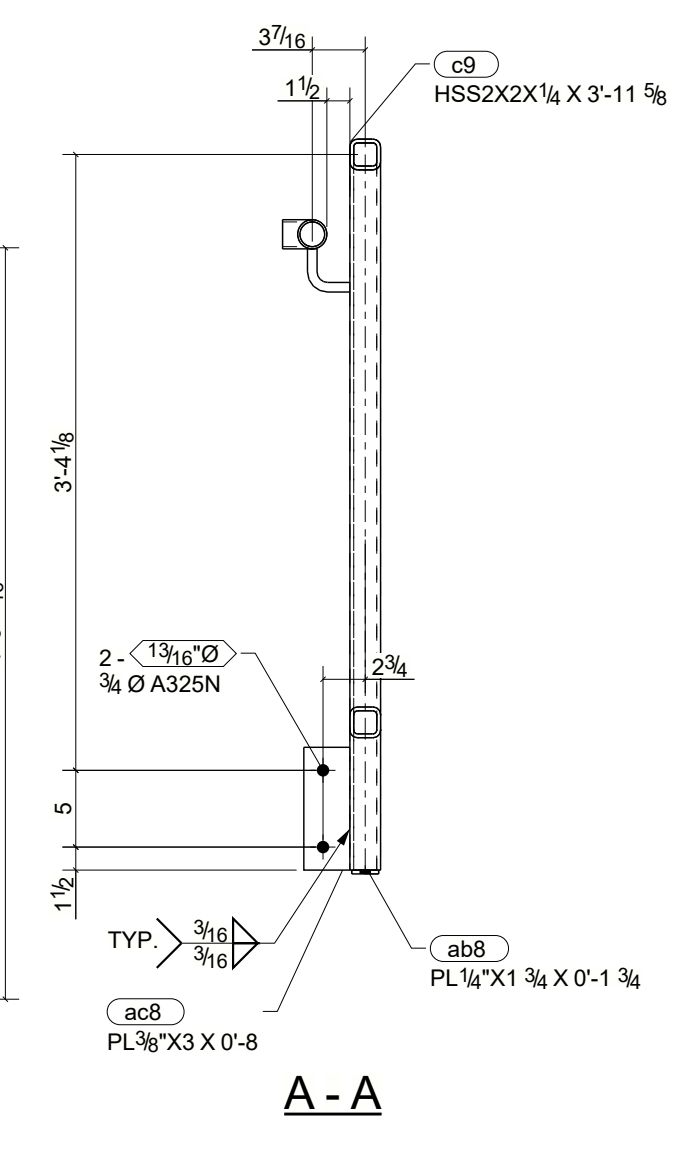
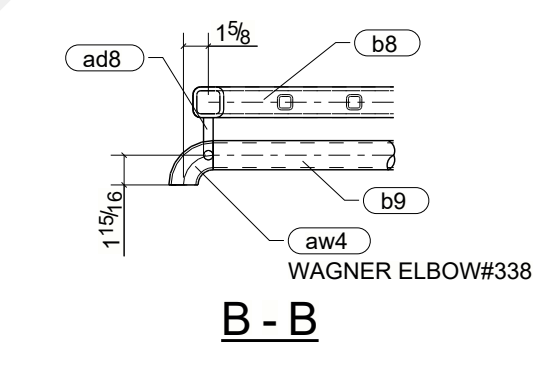
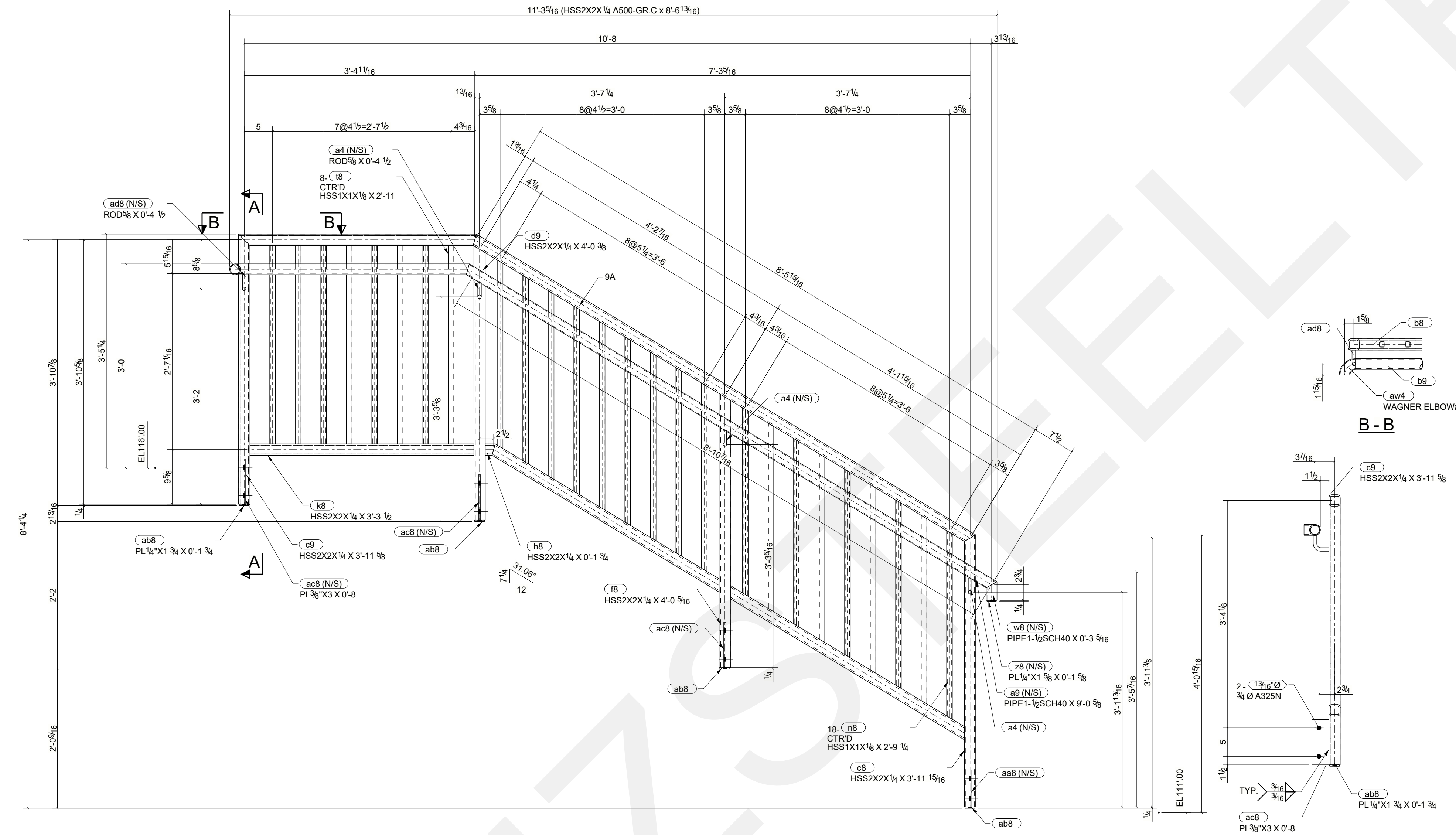

1 ~ HANDRAIL ~ 9A

SHOP NOTE
 1. ALL JOINTS BE SEAL WELDED AS REQUIRED
 2. ALL EXPOSED VENT HOLES TO BE PLUGGED AFTER GALVANIZING
 3. PROVIDE VENT/DRAIN HOLES (AS REQUIRED) VISIBLE ON THE UNDERSIDE OF RAILS