

BILL OF MATERIAL						FITTER	INSPECT.
SHIP MARK	PIECE MARK	QTY	DESCRIPTION	LENGTH	REMARKS		
	7A	1	HSS2X2X1/4	10'-11"	A500-GRC		
	f7	1	PL3/8"X2 1/2"	0'-7"	A36		
	h6	2	PL3/8"X2 1/2"	0'-7"	A36		
	k6	2	PL3/8"X2 1/2"	0'-8 1/4"	A36		
	a7	1	HSS2X2X1/4	1'-6 5/16"	A500-GRC		
	b6	30	HSS1X1X1/8	2'-11"	A500-GRC		
	b7	1	HSS2X2X1/4	1'-4 5/16"	A500-GRC		
	c6	2	HSS2X2X1/4	3'-3 5/8"	A500-GRC		
	d6	3	HSS2X2X1/4	3'-5 5/8"	A500-GRC		
	d7	3	HSS2X2X1/4	3'-5"	A500-GRC		
		10	1/2"Ø HILTI KWIK BOLT TZ	0'-5 1/2"	Site		
	7B	1	HSS2X2X1/4	4'-0"	A500-GRC		
	h6	1	PL3/8"X2 1/2"	0'-7"	A36		
	k6	2	PL3/8"X2 1/2"	0'-8 1/4"	A36		
	b6	18	HSS1X1X1/8	2'-11"	A500-GRC		
	c6	1	HSS2X2X1/4	3'-3 5/8"	A500-GRC		
	d6	2	HSS2X2X1/4	3'-5 5/8"	A500-GRC		
	g7	1	HSS2X2X1/4	3'-6"	A500-GRC		
	h7	1	HSS2X2X1/4	3'-10"	A500-GRC		
	m7	1	HSS2X2X1/4	3'-8"	A500-GRC		
		6	1/2"Ø HILTI KWIK BOLT TZ	0'-5 1/2"	Site		

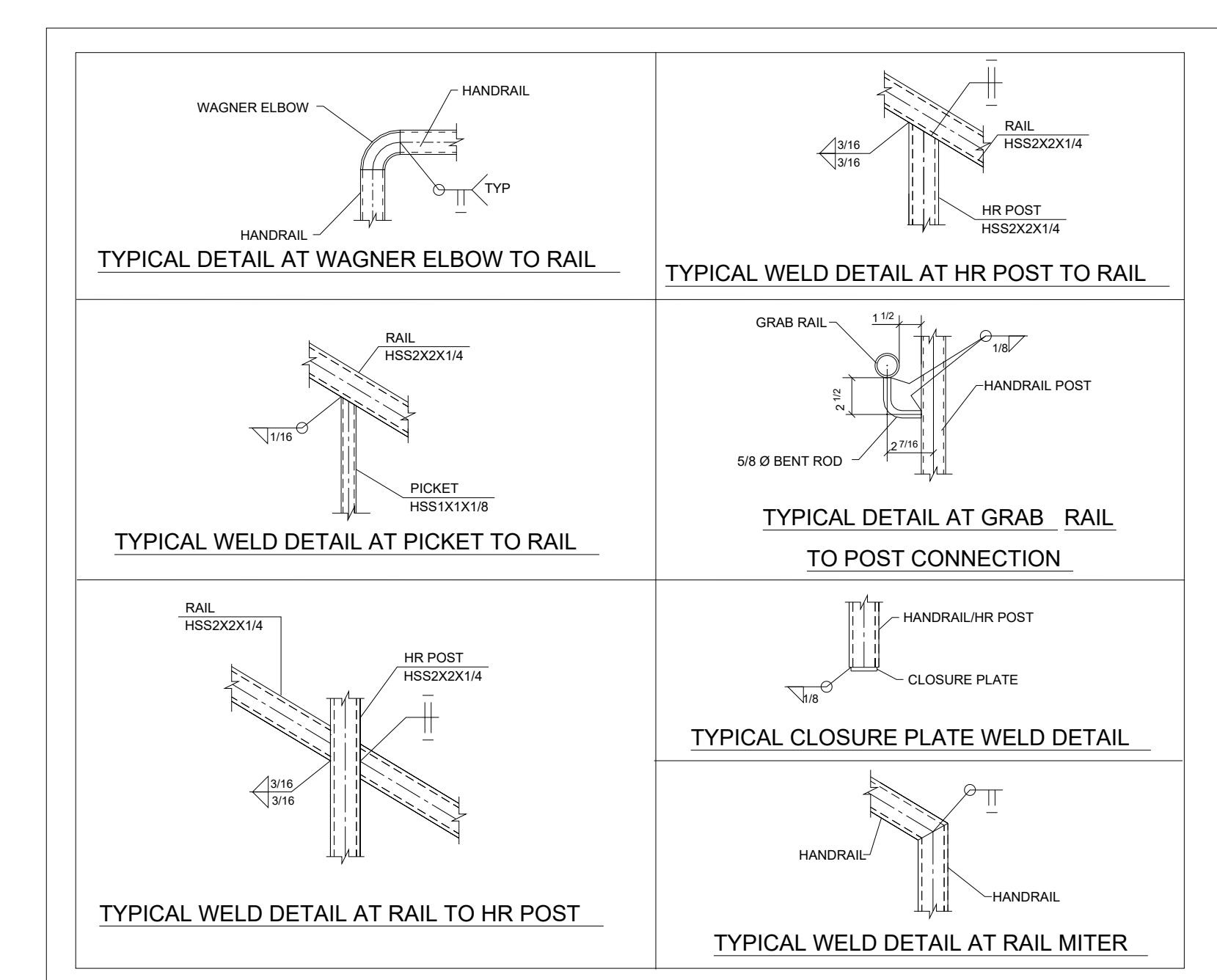

**SHOP NOTE**  
 1. ALL JOINTS BE SEAL WELDED AS REQUIRED  
 2. ALL EXPOSED VENT HOLES TO BE PLUGGED AFTER GALVANIZING  
 3. PROVIDE VENT/DRAIN HOLES (AS REQUIRED) VISIBLE ON THE UNDERSIDE OF RAILS