

BILL OF MATERIAL

SHIP MARK	PIECE MARK	QTY	DESCRIPTION	LENGTH	REMARKS	FITTER	INSPECT.
20A		7	PL1/8"X22 1/8"	3'-9"	A36		
20B		1	PL1/8"X11 3/16"	3'-9"	A36		
20C		1	PL1/8"X10 3/4"	3'-9"	A36		
20D		13	PL1/8"X22 3/16"	3'-9"	A36		
20E		1	PL1/8"X6 7/8"	3'-9"	A36		
20F		1	PL1/8"X13 5/8"	3'-9"	A36		

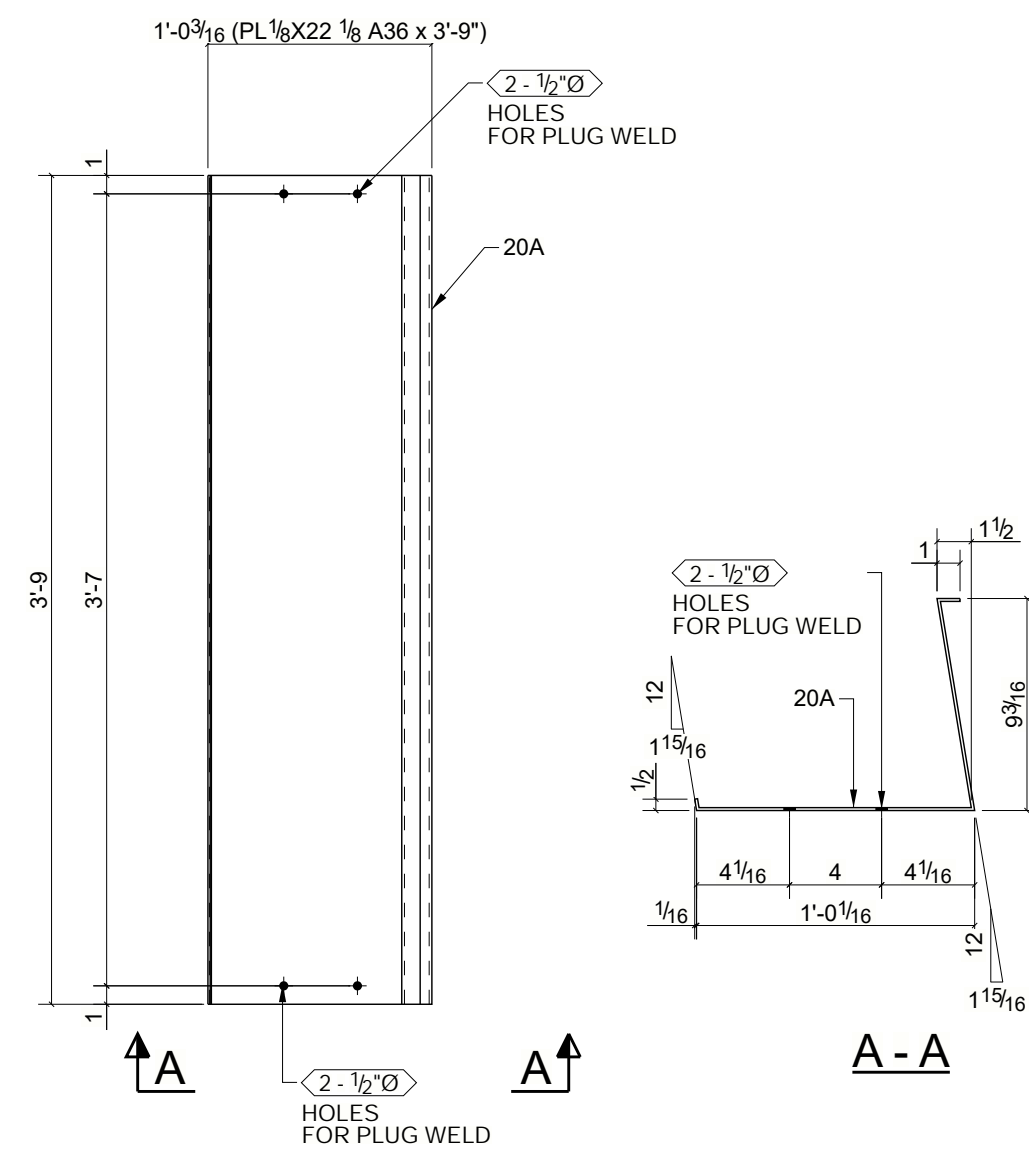

7 ~ TREAD PLATE ~ 20A

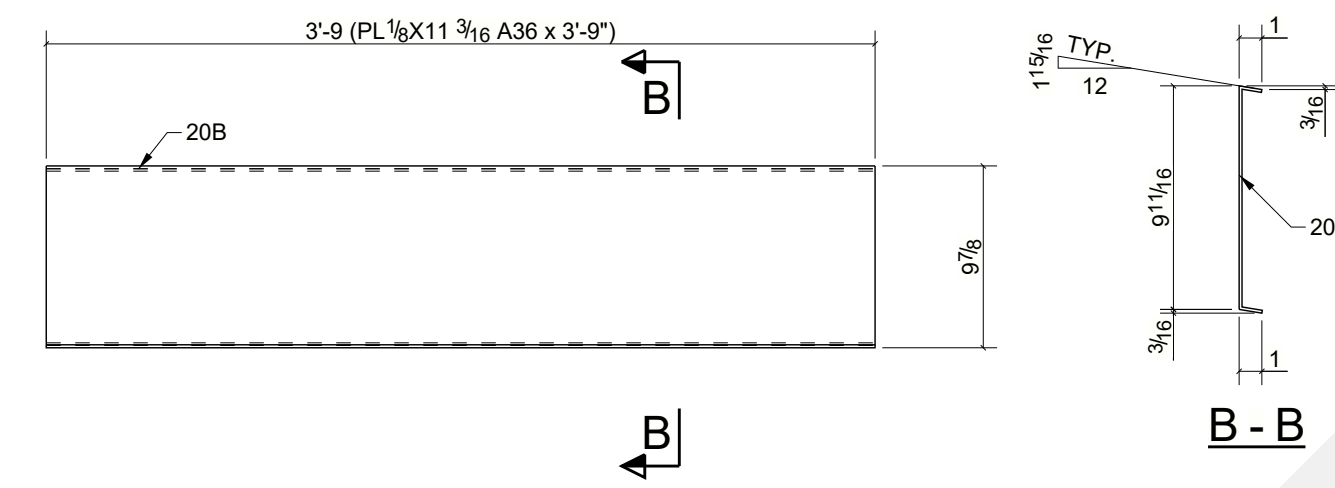

1 ~ TREAD PLATE ~ 20B

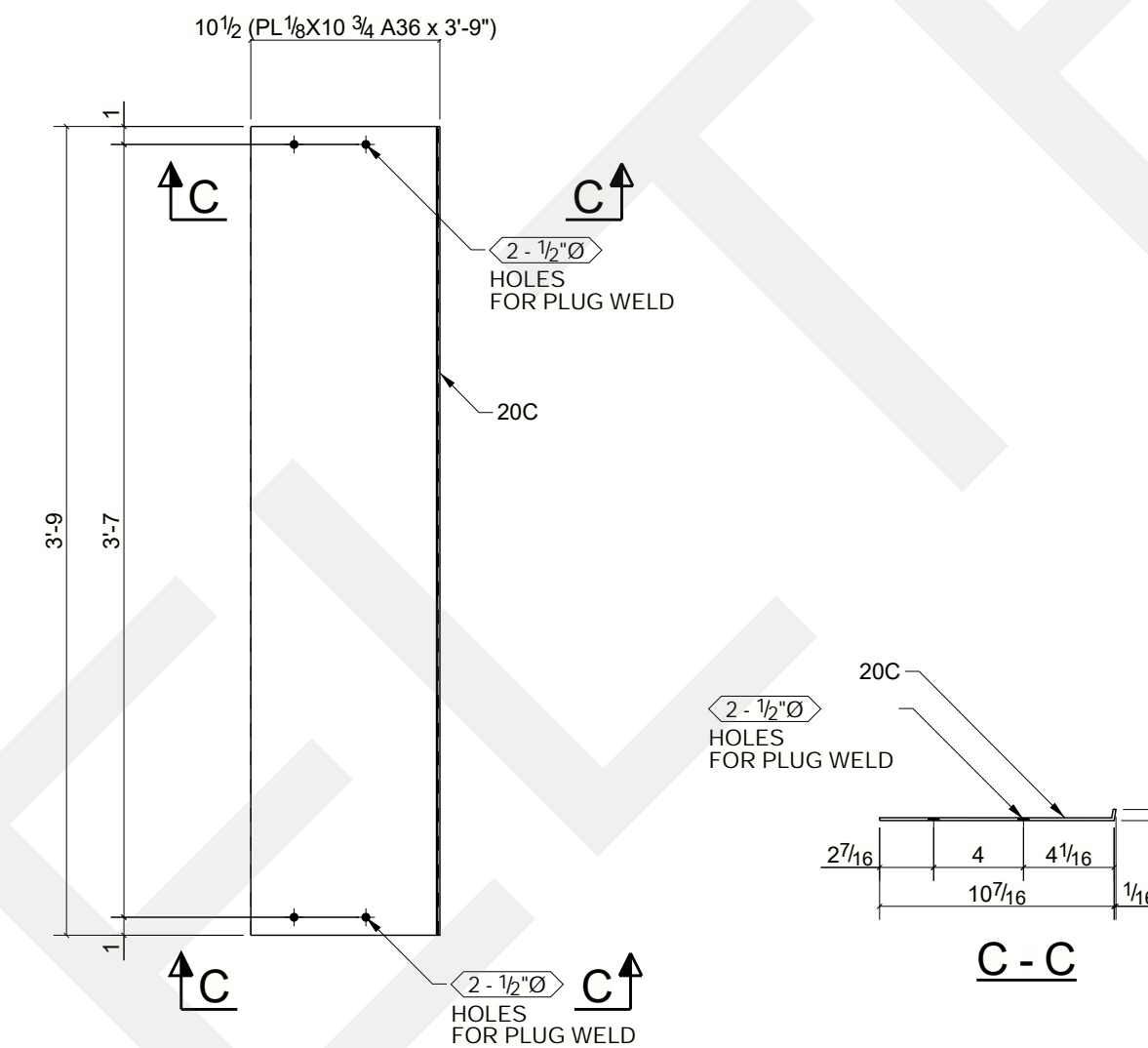

1 ~ TREAD PLATE ~ 20C

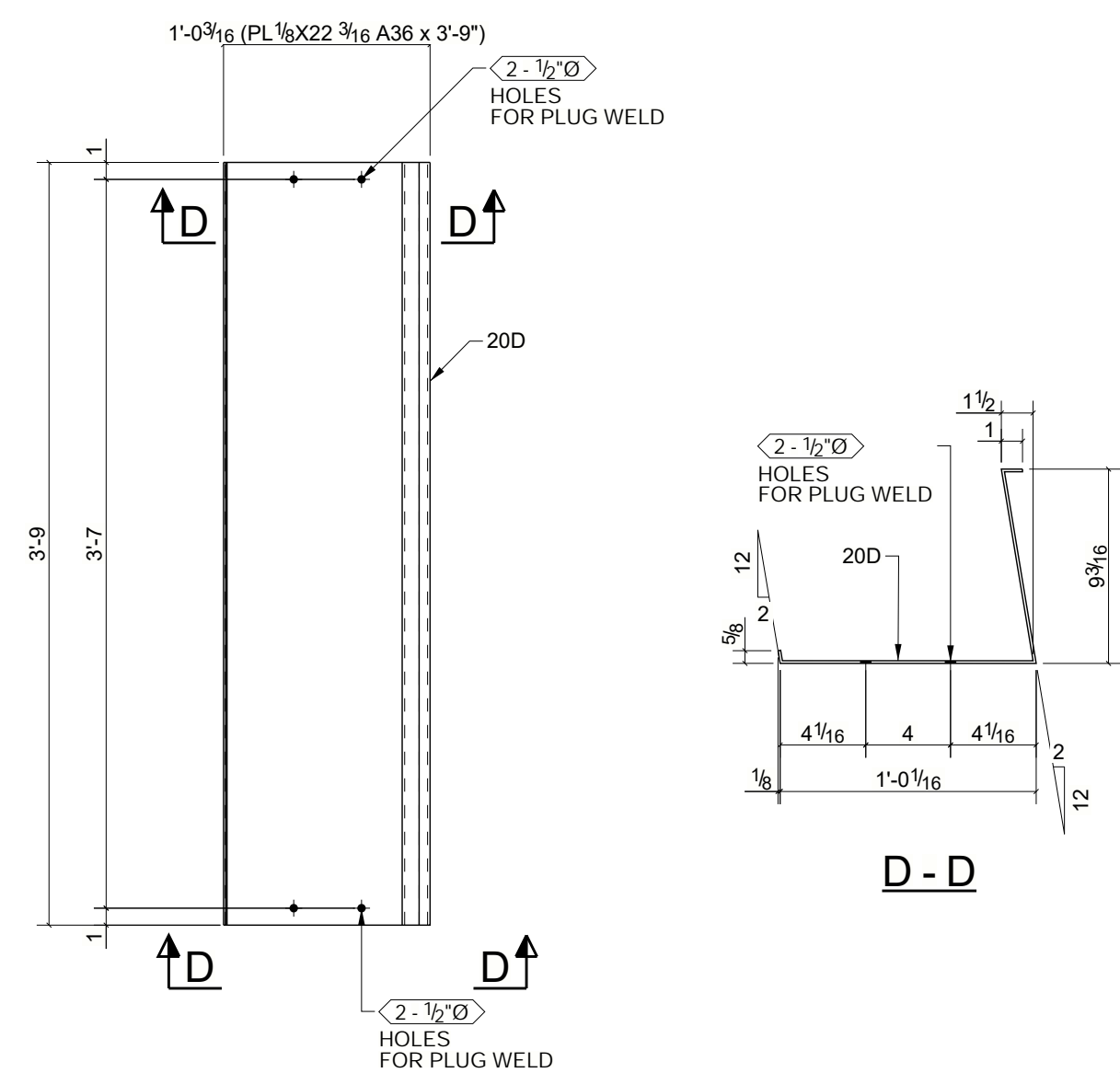

13 ~ TREAD PLATE ~ 20D

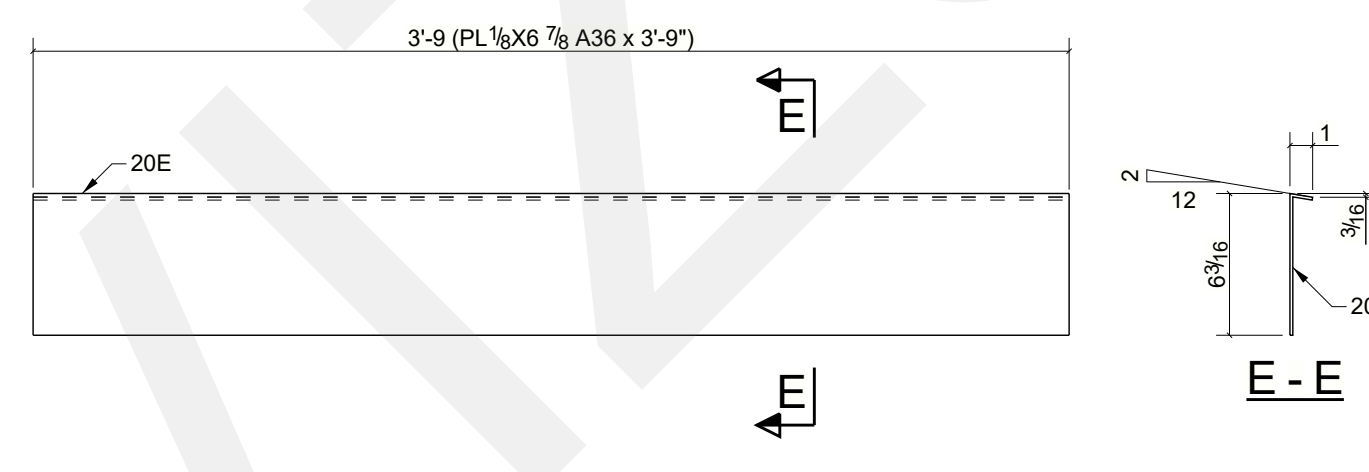

1 ~ TREAD PLATE ~ 20E

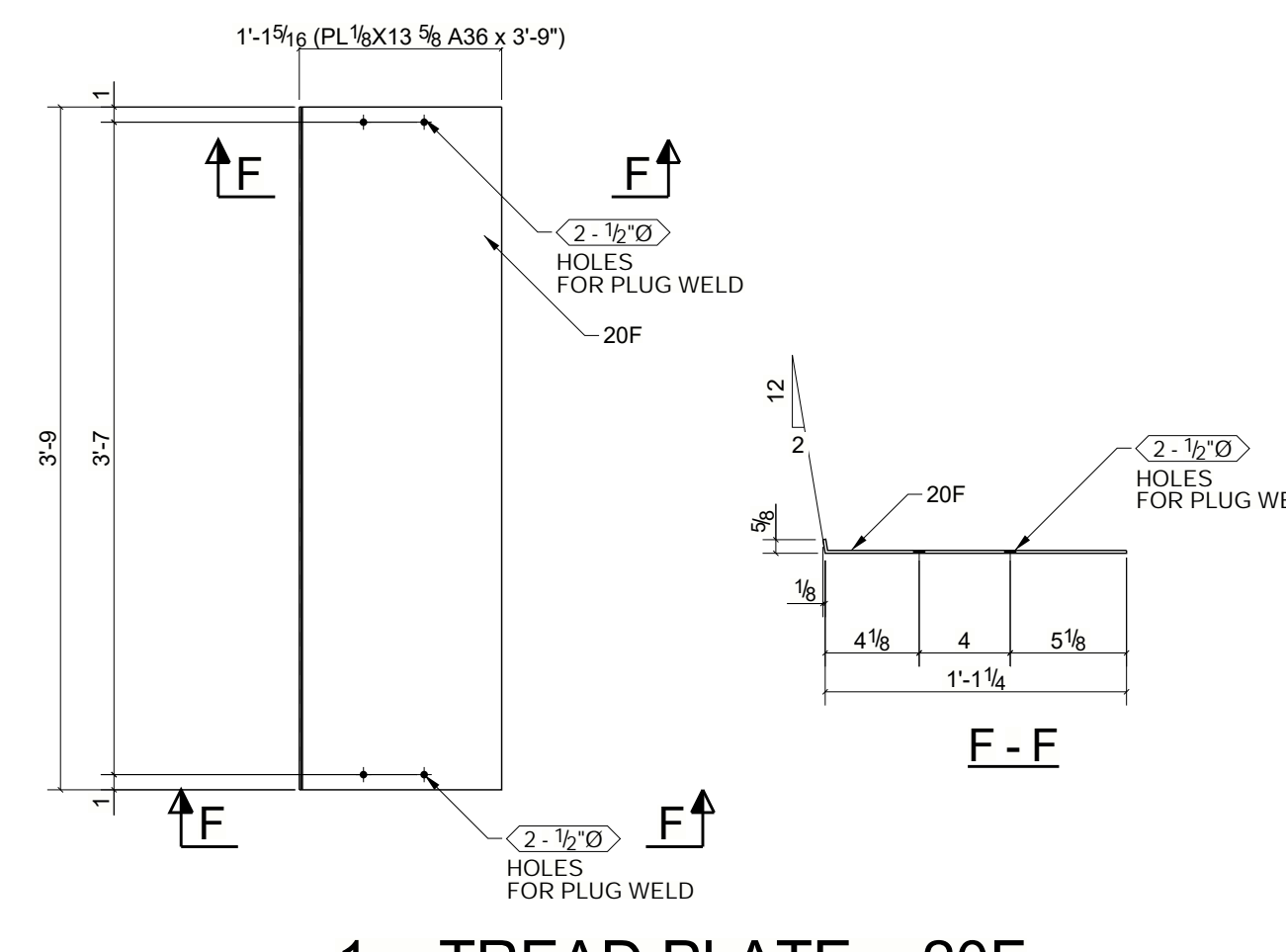

1 ~ TREAD PLATE ~ 20F